

KLOPFENSTEIN CHALLENGE EASEL (CH100) ASSEMBLY & SAFETY INFORMATION (Please read, see over)

Assembled Challenge Easel

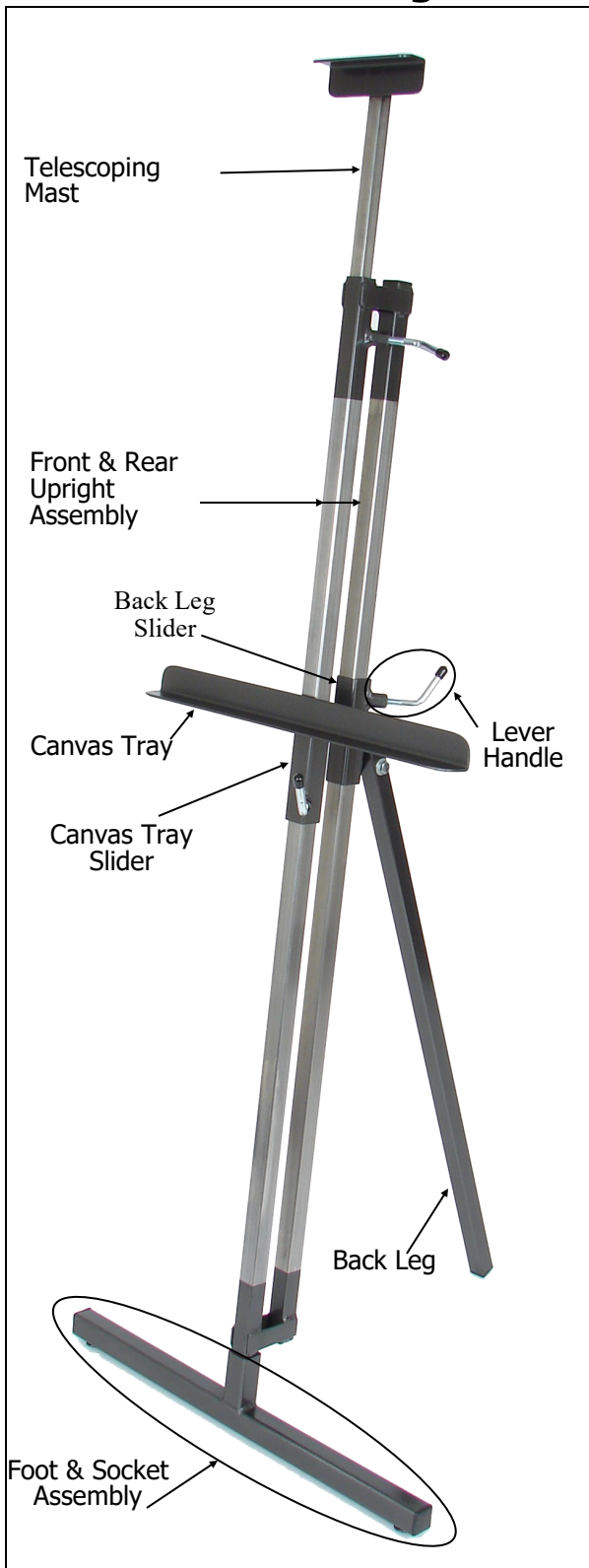

Easel Parts for Assembly

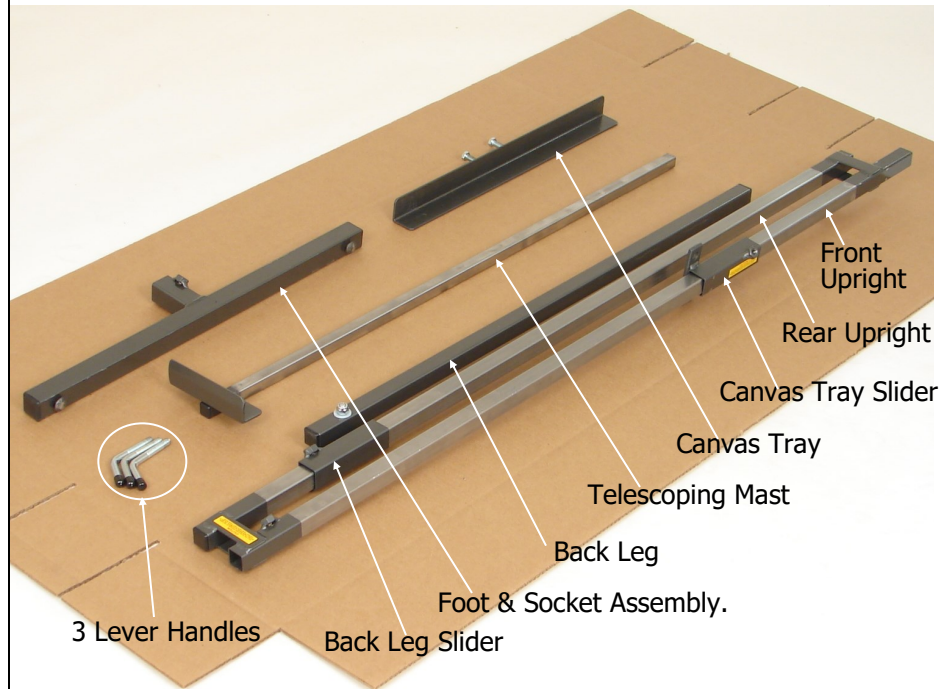

- 1 Remove all plastic wrap and lay your parts out for identification (see parts layout above & assembled easel left).
- 2 Thread a **Lever Handle** into the **Back Leg Slider** and the **Canvas Tray Slider** & tighten them so that the sliders are locked into place.
- 3 Insert the bottom end of the **Front Upright** into the **Foot Socket** and tighten the socket bolt securely with a 9/16", or an adjustable wrench (*socket bolt should face towards the back leg*).
- 4 Insert the **Telescoping Mast** into the top of the **Front Upright** and screw in the remaining **Lever Handle**.
- 5 Remove the 2 bolts from the back of the **Canvas Tray** & attach the **Canvas Tray** to the **Canvas Tray Slider**. Snug up one bolt then the other, back and forth till they are **evenly** & securely tightened. *Don't over-tighten.*

We recommend an occasional wiping down of the unpainted front & rear uprights with a rag or paper towel sprayed with WD-40.

Need Help? Call us at (419)884-2900 with questions or comments.

Safely Using The Klopfenstein-Built Challenge Easel

CAUTION: Klopfenstein painting and drawing equipment is made from all welded, heavy gage steel tubing to provide exceptional durability and rigid stability for studio work. Our equipment is heavier than similar sized wood equipment and you must therefore take care to hold & control the telescoping & sliding parts of our equipment securely when making adjustments. **Failure to control these parts could cause personal injury and / or damage to your equipment.**

ATTN: ART PROFESSIONALS & STUDENTS Prevent personal injury. Carefully read and follow all safety procedures shown in this guide for safely working with this equipment.

ANATOMY OF A CH100 EASEL

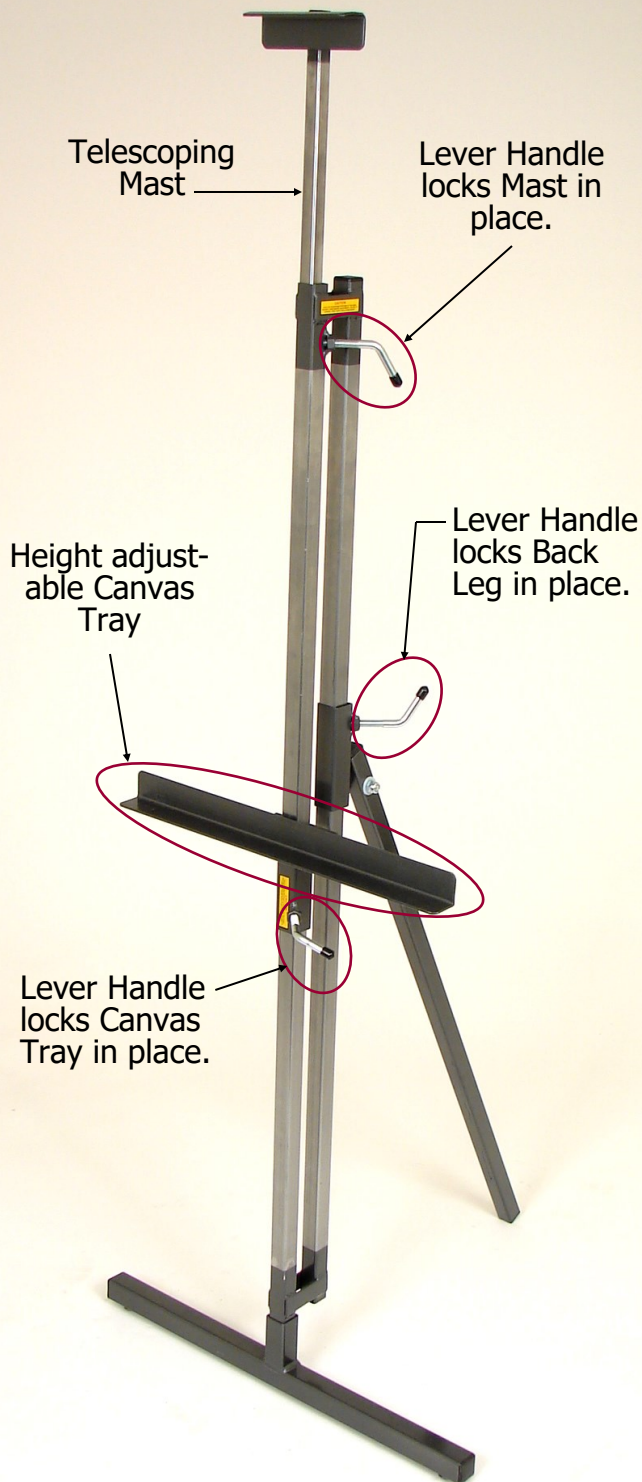

SAFELY ADJUSTING MAST HEIGHT

- 1) Hold the *telescoping* section of the mast **before** loosening the lever handle.
- 2) Holding the mast with one hand, loosen the lever handle, adjust the mast height and re-tighten the lever handle.

ALWAYS: lower the mast to its resting position at the end of each painting / drawing session.

ALWAYS: support the mast with one hand **before** making any height adjustments.

ALWAYS: re-tighten the lever handle(s) after **every** easel adjustment.



SAFELY ADJUSTING TILT ANGLE

- 1) Hold & support the easel **before** loosening the back leg Lever Handle.
- 2) Holding the easel with one hand, loosen the back leg Lever Handle, adjust the tilt angle and re-tighten the back leg Lever Handle.

ALWAYS: support the easel with one hand **before** making any tilt adjustments.

ALWAYS: support the Canvas Tray **before** making any height adjustments.

ALWAYS: re-tighten the lever handle(s) after **every** easel adjustment.

